

ENTRADA FLANGE  
 Detalhe Flange  
 Motor IEC Adapter Detail  
 Detalle Brida  
 (Sem escala/no scale/sin escala)

Detalhe entrada do motor  
 Shaft motor detail  
 Detalle entrada motor  
 (Sem escala/no scale/sin escala)

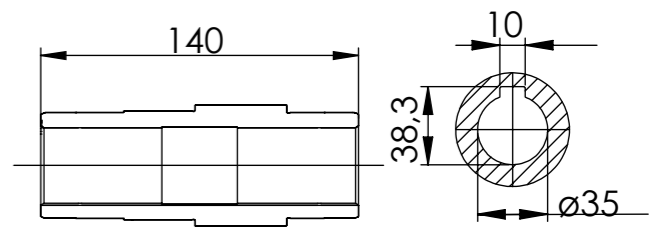
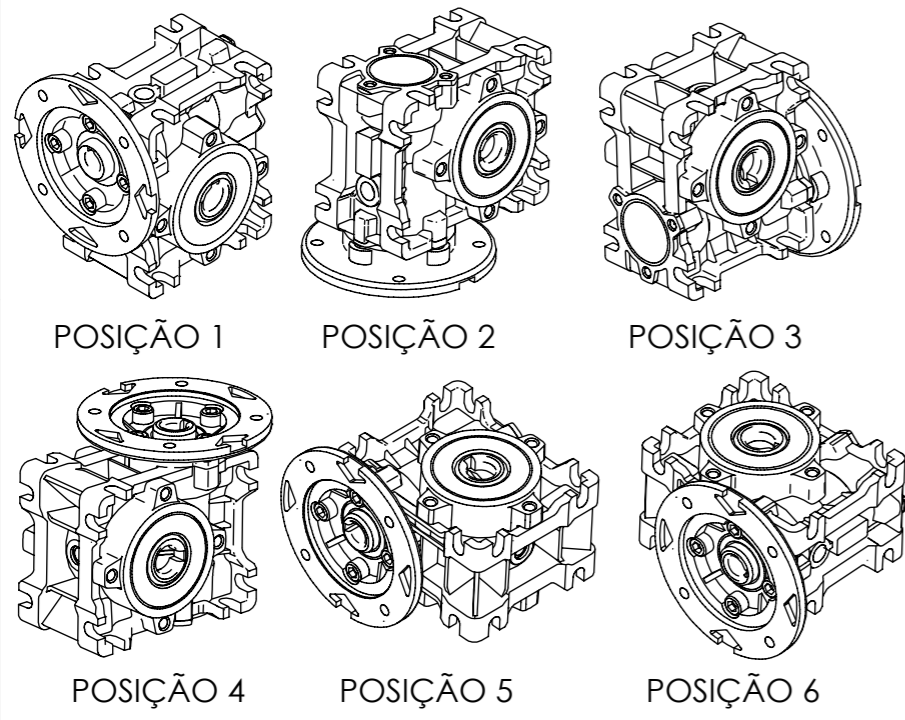

Detalhe eixo de saída  
 Outup shaft detail  
 Detalle del eje salida  
 (Sem escala/no scale/sin escala)

MASSA BRUTA/GROSS WEIGHT		MASSA LÍQUIDA/NET WEIGHT		ESCALA/SCALE	
ECM	LOC	RESUMO DE MODIFICAÇÕES SUMMARY OF MODIFICATIONS		EXECUTADO EXECUTED	VERIFICADO CHECKED
EXEC		<b>WCG01 90 1:40 NCH</b>		LIBERADO RELEASED	DATA DATE
VERIF/CHECKED					
LIBER/RELEASED					
DT LIBER/REL DT		FOL/SHEET 1 / 1			